

# INSTALLATION INSTRUCTIONS

**FOR USE ONLY WITH LOW VOLTAGE LANDSCAPE POWER UNITS THAT DO NOT EXCEED 25 AMPS, 15 VOLT MAXIMUM.**

**WARNING:** Luminaires must be installed in accordance with the National Electrical Code (NEC) and local codes. Failure to do so will void the warranty and may result in serious injury and/or damage to the luminaire.

**SAFETY WARNING:** Luminaire can become very hot depending on lamp wattage used. Lens and metal around lamp can become hot enough to blister hands. Particular care should be taken not to locate luminaires where small children can reach them if high wattage lamps are used.

**LUMINAIRES ARE NOT TO BE INSTALLED WITHIN 10 FT. (3.05M) OF A POOL OR SPA. SECONDARY CABLE IS NOT TO BE BURIED MORE THAN 6". WHEN USING MULTIPLE LUMINAIRES, LOAD IS NOT TO EXCEED THE TOTAL WATTS OF TRANSFORMER RATING. DO NOT USE EXTENSION CORDS ON POWER UNITS.**

**NOTE:** Always use UL recognized wire connectors for connections.

**NOTE:** Save these instructions for future reference.

**LUMINAIRE IS UL LISTED FOR ABOVE GROUND INSTALLATION ONLY.**



## LUMINAIRE MOUNTING FOR WALLS/SURFACES:

1. To prevent electrical shock, disconnect transformer from electrical supply before installation or service.

2. Using luminaire housing as a template, mark location of housing on wall or other mounting surface.

3. Cut hole in wall or other mounting surface to accept housing.

**NOTE:** Remove any insulation within 6" inches of where luminaire will be mounted.

4. Insert housing into cut hole and secure tightly to wall or other mounting surface.

**NOTE:** Position housing in wall so one of the screw bosses is oriented upward. This will provide optimum positioning of the lens cover when secured (see fig. 2).

**NOTE:** An optional wall support mounting bracket is available to aid in securing fixture in mounting surface.

5. Install cover plate to luminaire and tighten screws evenly.

6. Strip two leads from luminaire wire. Using two silicone filled safety connectors (provided), connect leads from luminaire to main supply cable leads.

7. Provide power to luminaire and check for proper operation.

## LUMINAIRE MOUNTING FOR FLUSH MOUNTING IN WALLS/SURFACES:

1. To prevent electrical shock, disconnect transformer from electrical supply before installation or service.

2. Using JBCP-150 housing as a template, mark location of housing on wall or other mounting surface.

3. Cut hole in wall or other mounting surface to accept housing.

**NOTE:** Remove any insulation within 6" of where luminaire will be mounted.

4. Install JBCP-150 concrete mounting guard making sure top edge of the ring lines up with top edge of lens cover. Secure side bands to bottom of fixture with #10 screws provided (side bands of JBCP-150 may be bent outward to adjust fit of top ring).

5. If running wire through conduit, UL listed flexible conduit is recommended for in and out connections to ease fixture position and adjustment during installation.

5a. Install conduit through 3/4" NPT holes in sides of luminaire using Teflon tape or other thread sealant. Using plug (provided), seal unused conduit entry if required.

5b. Pull electrical supply wires (line in) through conduit and luminaire. Pull wires long enough for manual connections with safety connectors (4" to 6" above the top rim of luminaire). See fig. 3.

5c. Insert housing into cut hole and secure tightly to wall or other mounting surface.

CONTINUED ON OTHER SIDE

**NOTE:** Due to temperature requirements in wiring compartment, UL listed THHN stranded copper electrical wire is recommended for electrical supply

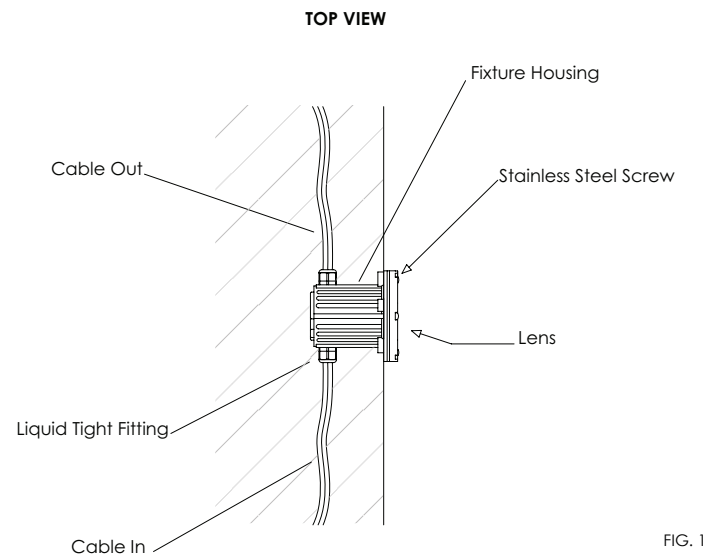

FIG. 1

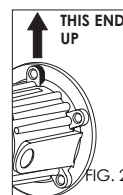

FIG. 2

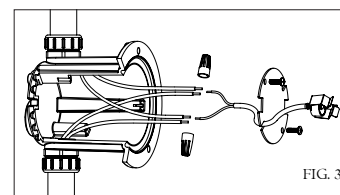

FIG. 3

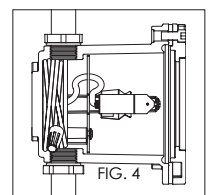

FIG. 4

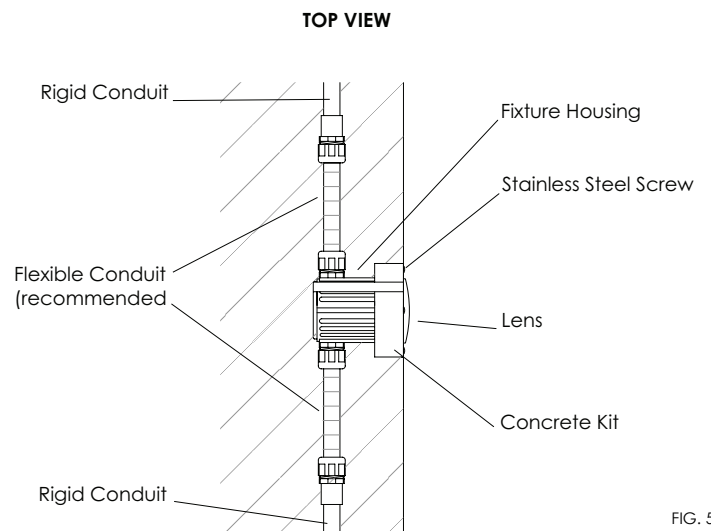

FIG. 5

Vista Professional Outdoor Lighting reserves the right to modify the design and/or construction of the fixture shown without further notification.

wires.

5d. Make wire connections to luminaire as required using the safety connectors provided.

5e. Coil wire leads along bottom of fixture and close wiring compartment as shown in fig. 4.

NOTE: Position housing in wall so one of the screw bosses is oriented upward. This will provide optimum positioning of lens cover when secured. See fig. 2.  
NOTE: An optional wall support mounting bracket is available to aid in securing fixture in mounting surface.

6. Install lens cover to luminaire and tighten screws evenly.

7. Strip two leads from luminaire wire. Using two silicone filled safety connectors (provided), connect leads from luminaire to main supply cable leads (see above).

8. Provide power to luminaire and check for proper operation.

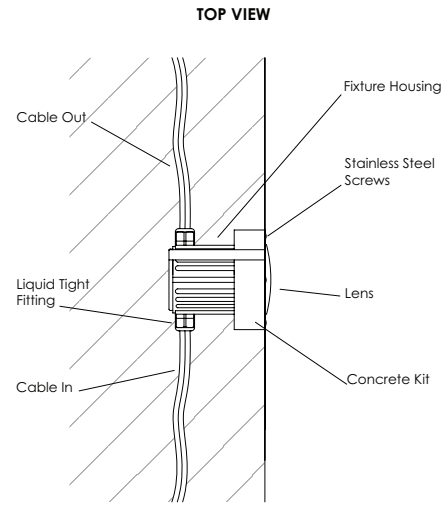

FIG. 6

**WARNING: TO REDUCE THE RISK OF FIRE, OR INJURY TO PERSONS:**

1. Turn off/unplug and allow to cool before replacing lamp.
2. Lamps get hot quickly! Contact only switch/plug when turning on.
3. Do not touch hot lens, guard or enclosure.

4. Keep lamp away from material that may burn.
5. Do not touch the lamp at any time. Use a soft cloth. Oil from the skin may damage lamp.
6. Do not operate luminaire fitting with a missing or damaged cover.

**LAMP INSTALLATION/REPLACEMENT:**

**CAUTION:** Do not exceed maximum wattage marked on luminaire label.

1. To prevent electrical shock, disconnect transformer from electrical supply before service.
2. Loosen cover screws and remove cover.
3. Remove gasket.
4. Replace lamp with correct wattage and type marked on fixture label.

**NOTE: DO NOT** touch Halogen lamp with bare hands. Always use soft cloth or the plastic wrapping (if available) from the lamp to handle the lamp.  
5. Clean gasket channel and re-install a new gasket.

strongly recommends replacing the gasket with a new one each time the fixture is unsealed for maintenance. A replacement gasket for future use is provided for your convenience. Additional gaskets for your maintenance kit may be purchased through your local Vista Professional Outdoor Lighting distributor.

**NOTE:** Lamp bracket may be adjusted for lamp aiming. Loosen bracket screws (1), then manually tilt bracket (2) to desired position. Tighten bracket screws afterward to secure lamp position.  
6. Re-install cover and tighten the cover screws evenly.

**NOTE:** As a recommended practice for installers of all ingrade luminaires, Vista

**LED:**

The operating voltage range for this LED luminaire is 6 - 15 volt AC. The Vista electronic driver ensures the LED operates at the intended lumen output while receiving voltage as low as 6 volts, and as high as 15 VAC, resulting in a balanced lumen output from the first fixture to the last. Eliminating the dimness issues often attributed to voltage drop.

**Note: Operating voltage range for LED luminaries will vary depending on model, style and total number of LEDs. To help determine the operating voltage range for each Vista luminaire, always consult factory's specification sheet and/or installation instructions before installation.**

**LED ENGINE INSTALLATION/REPLACEMENT:**

1. To prevent electrical shock, disconnect transformer from electrical supply before service.
2. Loosen cover screws and remove cover.
3. Remove gasket.
4. Remove stainless steel locking/expansion ring.
5. Pull field replaceable LED engine assembly out of secondary heat sink.
6. Disconnect Connector Assembly.
7. Connect new field replaceable LED engine to connector assembly.
8. Reinstall LED engine and secure with locking/expansion ring.
9. Clean gasket channel and reinstall a new gasket.
10. Reinstall cover and tighten the cover screws evenly.

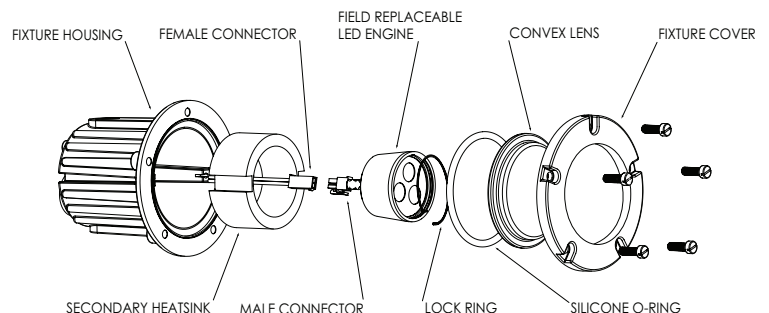

Vista Professional Outdoor Lighting reserves the right to modify the design and/or construction of the fixture shown without further notification.